

LED BEACON

Permanent Mount (Bolt Mount / Pipe Mount)

OPERATION

RED: To +VDC

BLACK: To Chassis Ground (-)

YELLOW: Flash patterns & Synchronization

Connect YELLOW wires of all units together for synchronization

*All units must be set at the same pattern

Momentarily apply +VDC to YELLOW wire:

- once for next pattern
- quickly 3 times for reset

Note: Make sure to cover all unused bare wires.

FP#	FLASH PATTERNS
1	Double (2Hz)
2	Single (2Hz)
3	Quad (2Hz)
4	Single
5	Double
6	Quad
7	Quint
8	Mega
9	Ultra
10	Single-Quad
11	Single H/L
12	Steady

Note: This unit may not be factory set at FP#1.

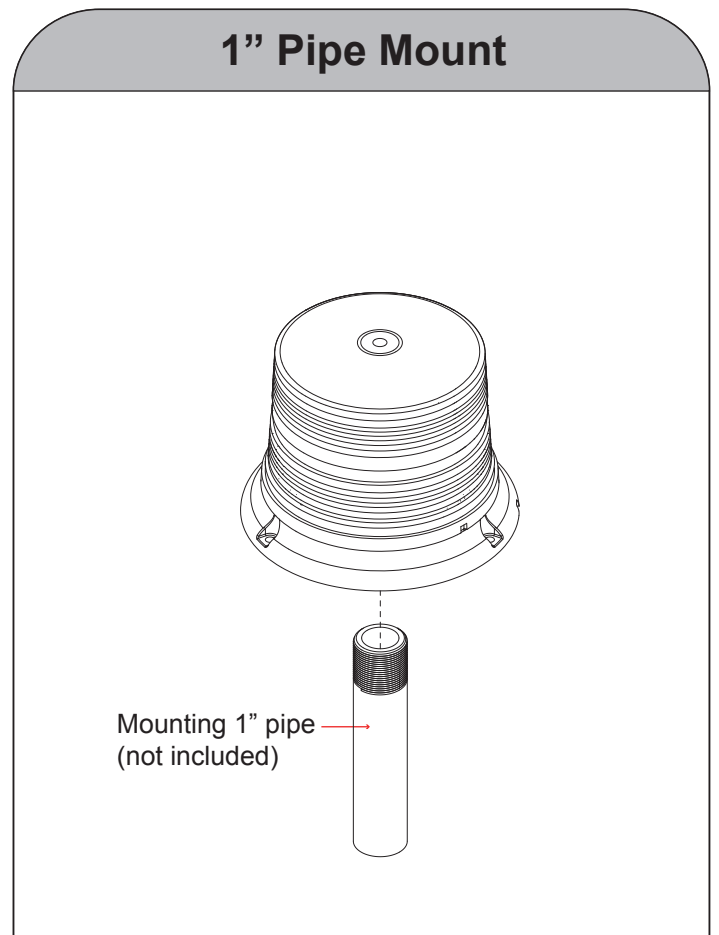
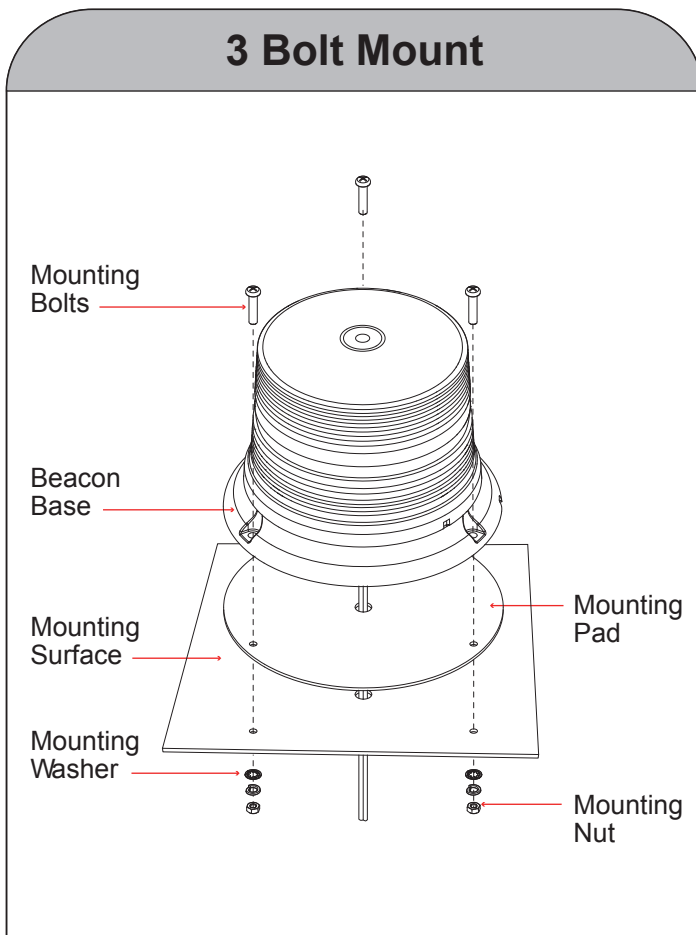

LED BEACON

Temporary Mount (Magnetic Mount / DIN Mount)

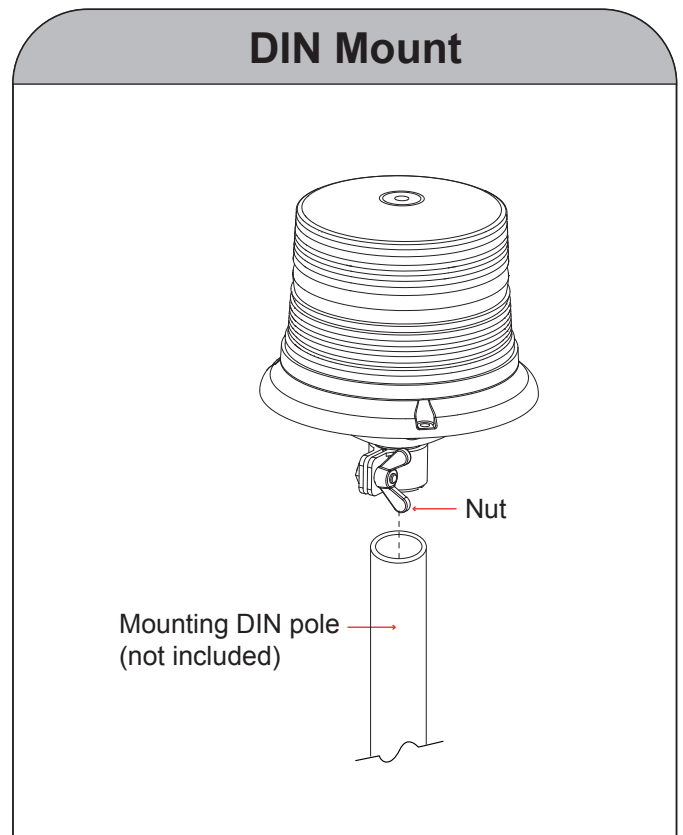
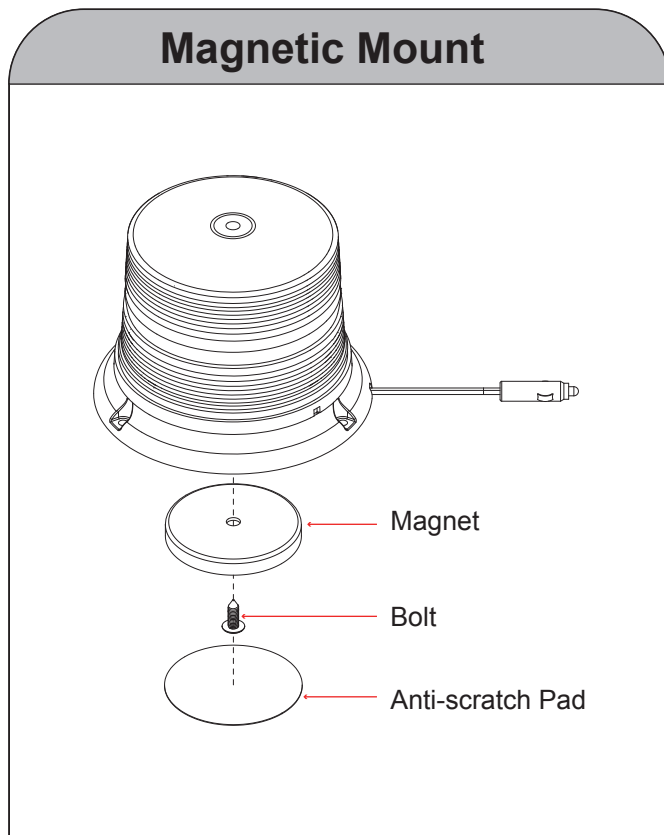

1. Open beacon

Twist dome counter-clockwise **B**, then lift dome to open.

2. Change pattern

Momentarily push red button to change to next flash pattern. (see flash patterns chart)

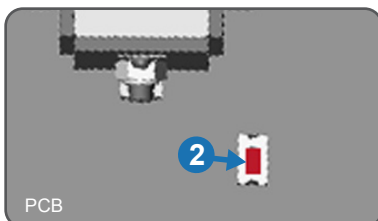

3. Close beacon

Align dome indent **A** with base **B**, then twist clockwise **C** to close.

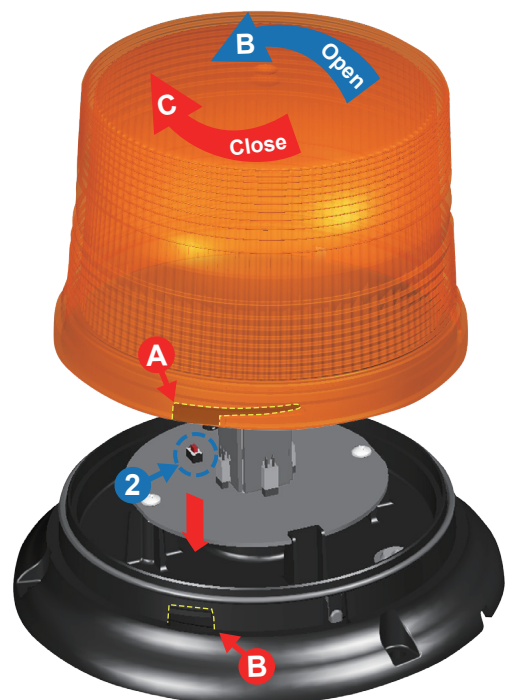

WARNING: It is not recommended to use magnetically mounted warning devices on outside of vehicles in motion. Usage is at the sole risk and responsibility of the user.